

SHOEBASE PLAN
CAST ALUM ALLOY A-356-T6

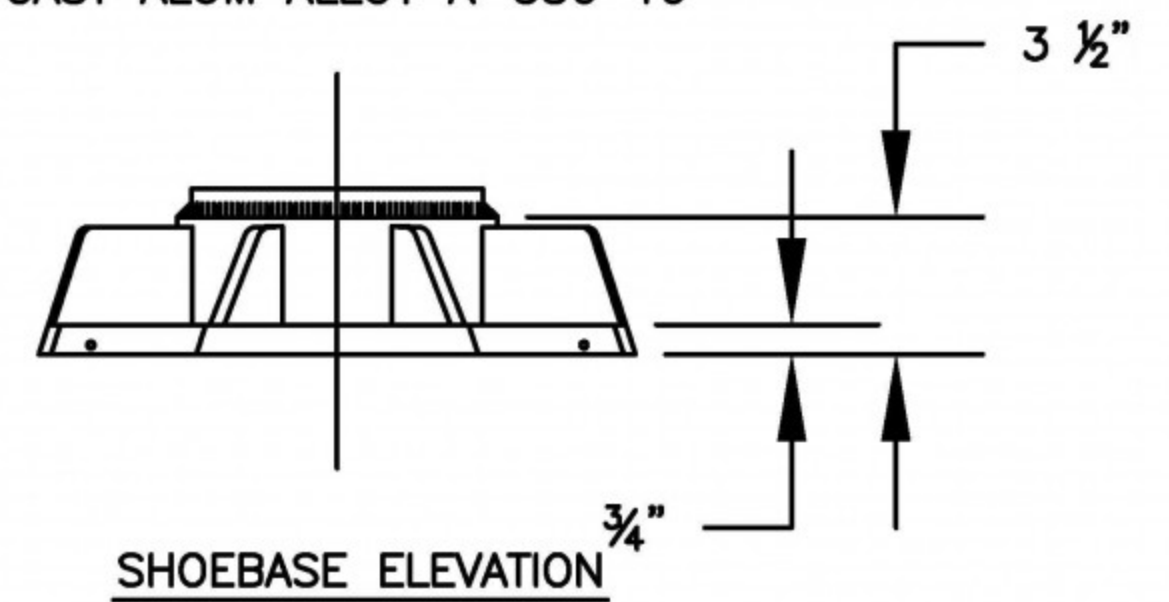

ALUMINUM FLAGPOLE WITH SHOEBASE